

**LION**  
technology



## **Electric tow tractor** **EZS 570-5100**

**Towing capacity: 7000-10000 kg**

**JUNGHEINRICH**

# EZS 570-5100

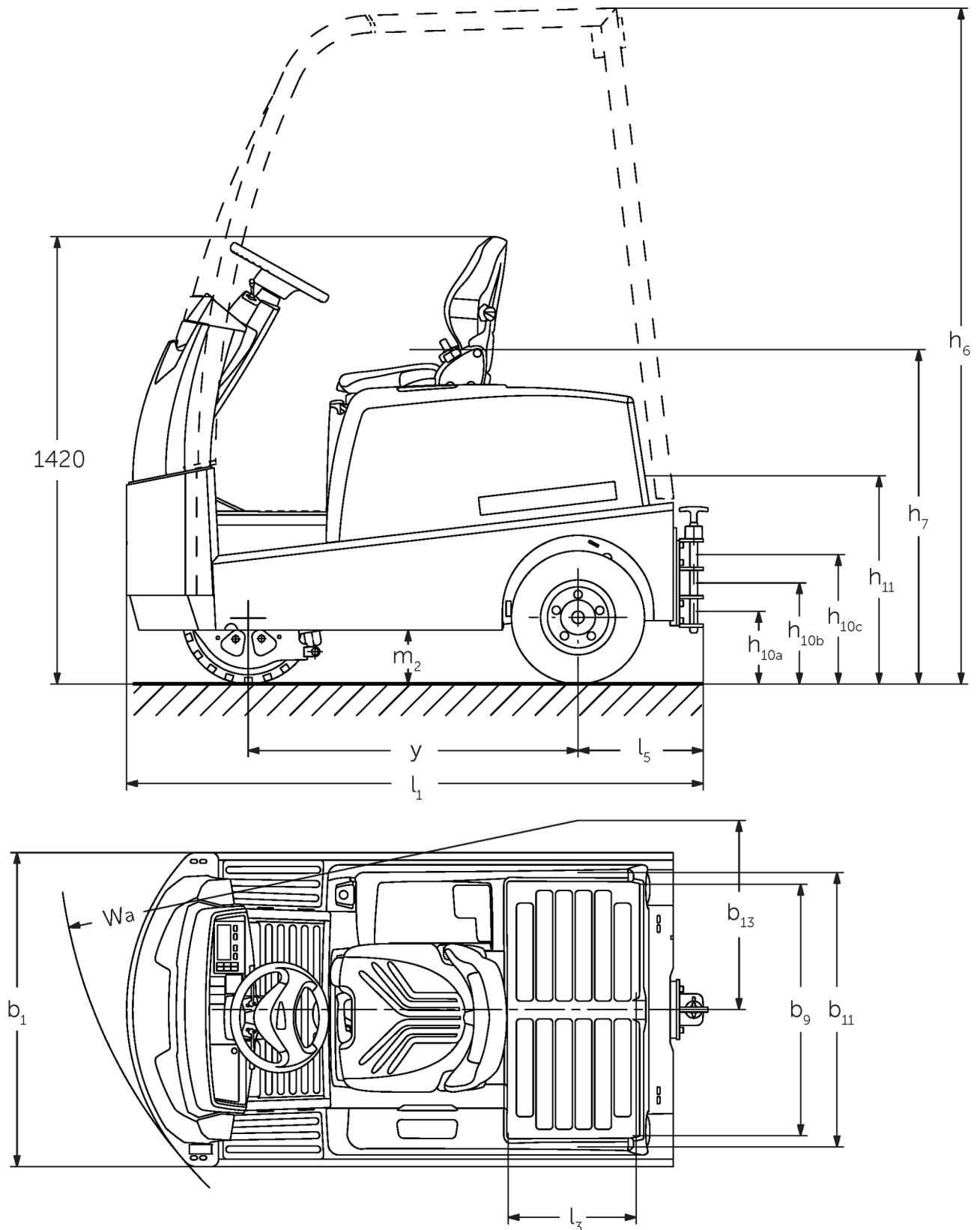

EZS 580, technical drawing, data sheet

# EZS 570-5100

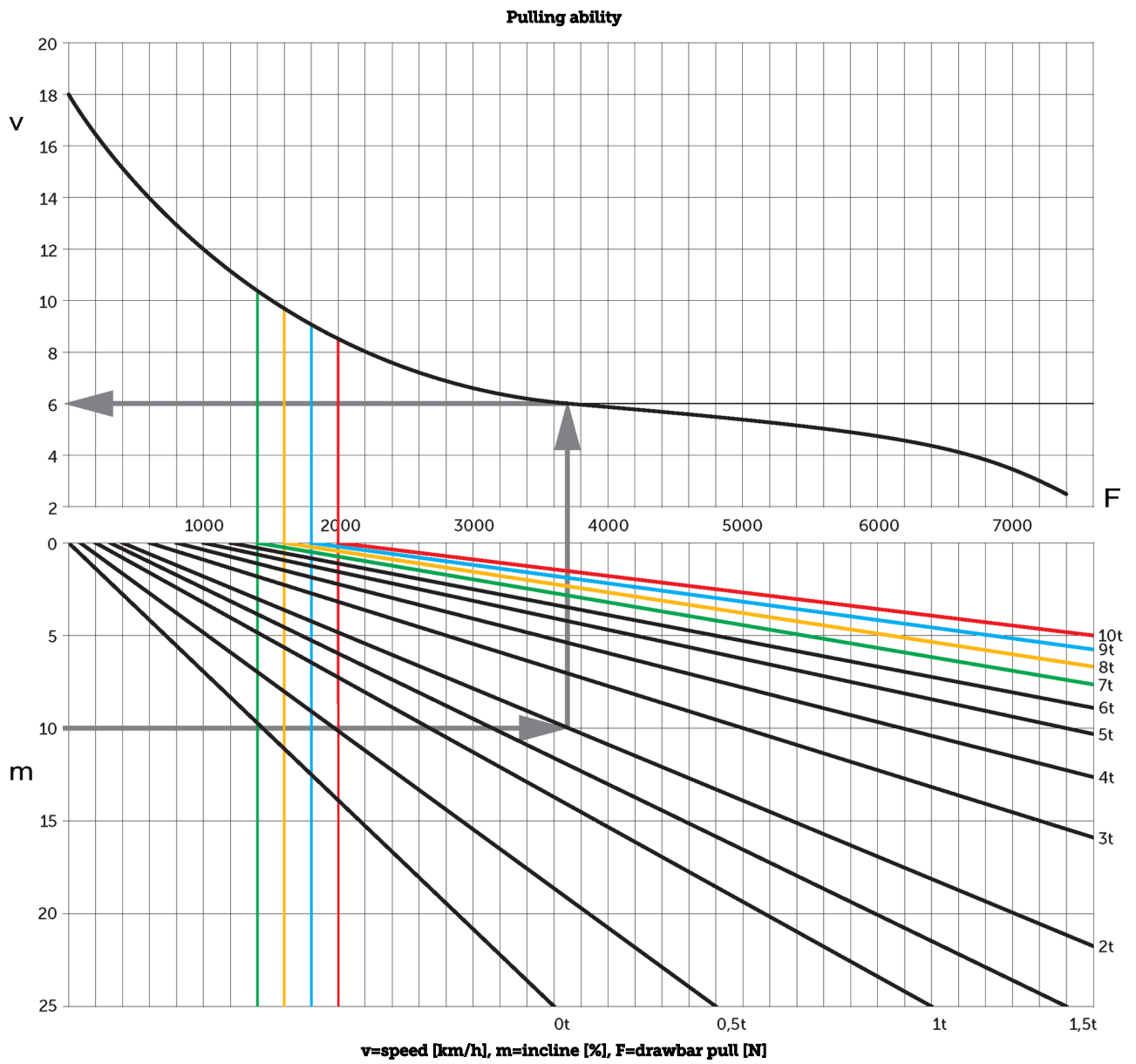

# VDI table

Stand-on: 11/2021

Characteristic	1.1	Manufacturer (abbreviated description)	Jungheinrich							
			EZS 570	EZS 580	EZS 590	EZS 5100 XL	EZS 570 XL	EZS 580 XL	EZS 590 XL	
	1.2	Manufacturer's type designation								
	1.3	Drive	Electric							
	1.4	Operation	Seat							
	1.5.3	Towing capacity	Q kg	7000	8000	9000	10000	7000	8000	9000
	1.7	Rated drawbar pull	N	1400	1600	1800	2000	1400	1600	1800
	1.9	Wheelbase	y mm	1035			1250			
Weights	2.1.1	Service weight (incl. battery)	kg	1260	1320	1410	1825	1620	1675	
	2.3	Axle load unladen front/rear	kg	580 / 680	580 / 740	620 / 790	880 / 945	780 / 840	835 / 840	
Wheels/suspension system	3.1	Tyres		Super-elastic (SE)						
	3.2	Tyre size, front		4.00-8	16x6-8		16x6-8	16x6-8		
	3.3	Tyre size, rear		4.00-8						
	3.5	Wheels, number front/back (x=driven)		1 / 2x						
	3.6	Tread width, front	b <sub>10</sub> mm	0		-	0			
	3.7	Tread width, rear	b <sub>11</sub> mm	870						
Basic dimensions	4.7	Height of overhead guard (cab)	h <sub>6</sub> mm	2150			2140			
	4.8	Seat height/stand height	h <sub>7</sub> mm	1040						
	4.12	Coupling height	h <sub>10</sub> mm	240						
	4.12.1	2. Coupling height	mm	330						
	4.12.2	3. Coupling height	mm	420						
	4.13	Loading height, unladen	mm	650	640		650	640		
	4.16	Loading area length	l <sub>3</sub> mm	400						
	4.18	Loading area width	b <sub>9</sub> mm	795						
	4.19	Overall length	l <sub>1</sub> mm	1828			2048			
	4.21.1	Overall width	b <sub>1</sub> mm	996						
	4.32	Ground clearance centre of wheelbase	m <sub>2</sub> mm	160	130		160			
	4.35	Turning radius	W <sub>a</sub> mm	1652			1866			
4.36	Smallest pivot point distance	b <sub>13</sub> mm	600			665				
Performance data	5.1	Travel speed laden/unladen	km/h	9 / 18	8.5 / 18		7.5 / 18	9 / 18	8.5 / 18	
	5.5	Drawbar pull laden/unladen	N	1400 / 1400	1600 / 1600	1800 / 1800	2000 / 2000	1400 / 1400	1600 / 1600	1800 / 1800
	5.6	Max. drawbar pull laden/unladen	N	5500 / 5500	6500 / 6500	7500 / 7500	7600 / 7600	5500 / 5500	6500 / 6500	7500 / 7500
	5.10	Service brake		electric						
E-motor/Electronics	6.1	Drive motor, performance S2 60 min	kW	4.5						
	6.4	Battery voltage/nominal capacity	V / Ah	48 / 375			48 / 625			
	6.5	Battery weight	kg	575			860			
	6.6.1	Energy consumption according to EN cycle	kWh/h	1.33	1.5	1.67	1.84	1.33	1.5	1.67
	6.6.2	CO2 equivalent as per EN 16796	kg/h	0.7	0.8	0.9	1	0.7	0.8	0.9
Other	8.1	Type of drive control		Impulse/AC						
	10.7	Sound level as per EN12053, operator's ear	dB (A)	62						

- This data sheet according to VDI guideline 2198 only states the technical values of the standard truck. Different tyres, other masts, additional equipment etc. may result in different values.

- VDI no. 5.7: see tow load diagram
- VDI no. 5.8: see tow load diagram
- VDI no. 6.6: the energy consumption applies to the rated load

The German production facilities in  
Norderstedt, Moosburg and Landsberg  
are certified.

ISO 9001  
ISO 14001

Jungheinrich fork lift trucks meet  
European safety requirements.



 **JUNGHEINRICH**

The Jungheinrich logo, featuring a red upward-pointing arrow above the word 'JUNGHEINRICH' in a bold, black, sans-serif font.