



Electric tow tractor

EZS 010

Towing capacity: 1000 kg

JUNGHEINRICH

EZS 010

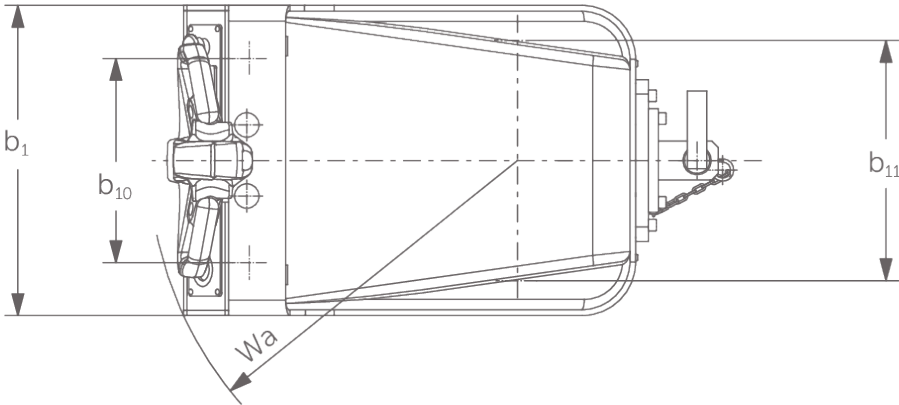
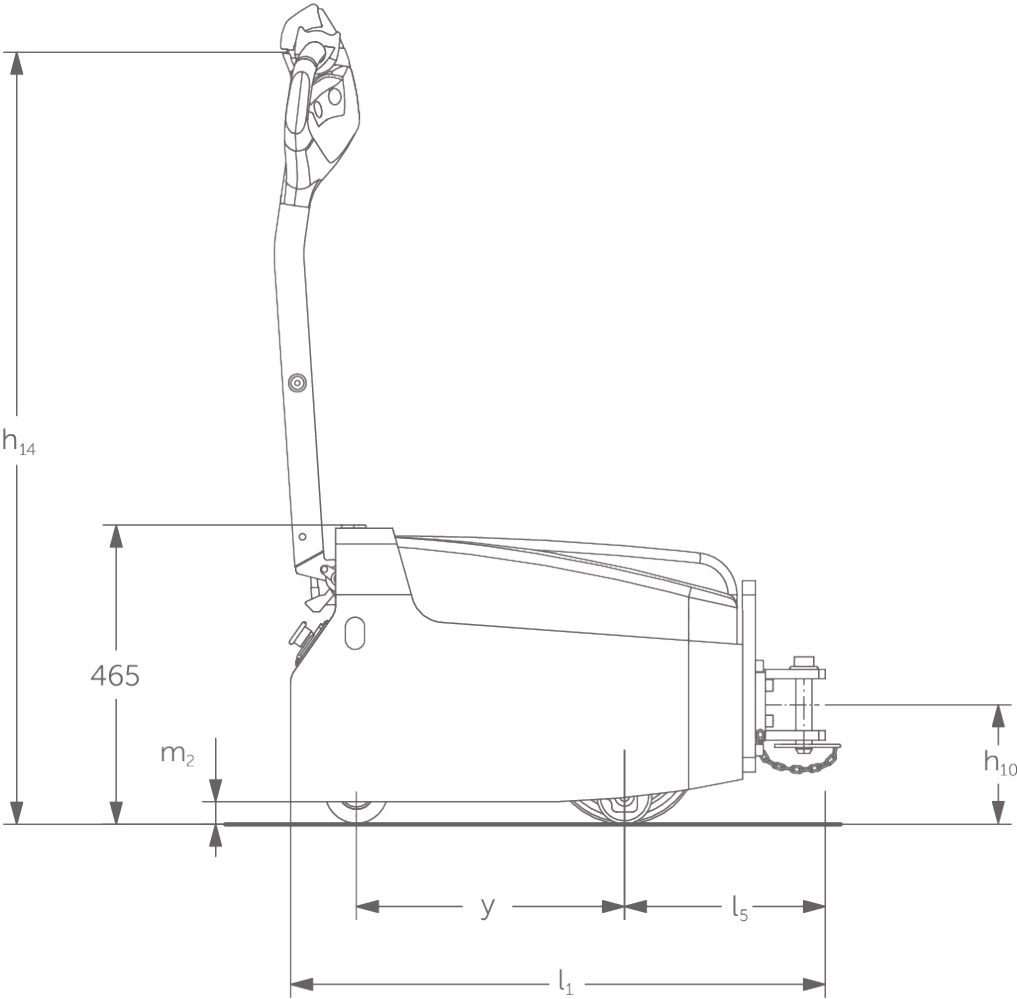

EZS 010

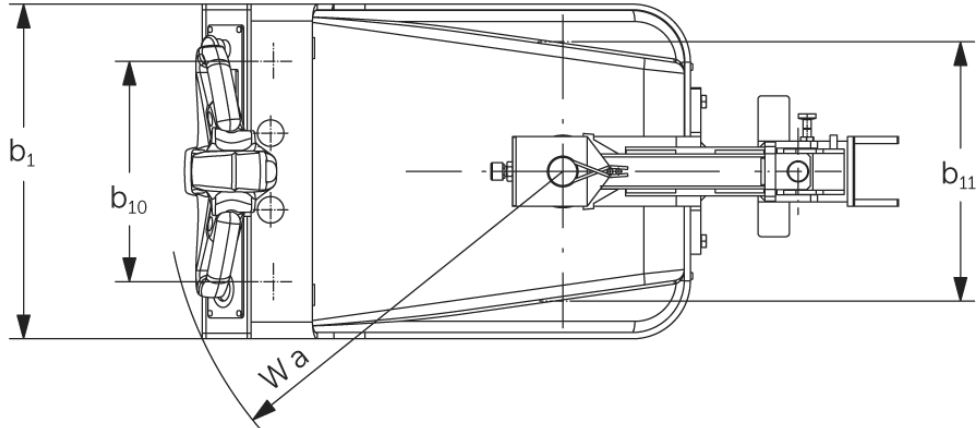
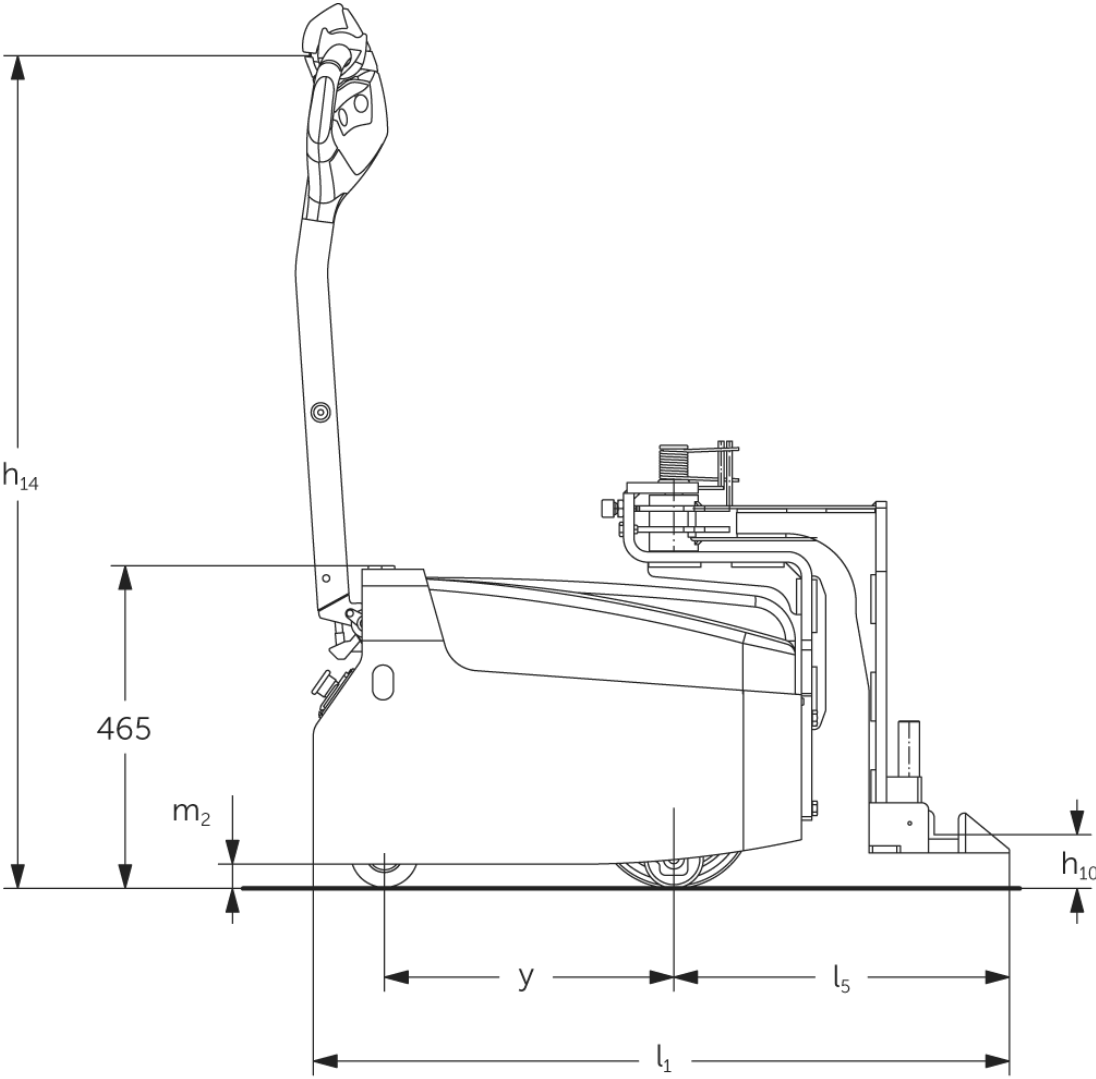

VDI table

Stand-on: 11/2021

Characteristic	1.1	Manufacturer (abbreviated description)		Jungheinrich	
	1.2	Manufacturer's type designation		EZS 010	
	1.3	Drive		Electric	
	1.4	Operation		Pedestrian	
	1.5.3	Towing capacity	Q	kg	1000
	1.7	Rated drawbar pull		N	200
	1.9	Wheelbase	y	mm	415
Weights	2.1.1	Service weight (incl. battery)		kg	190
	2.3	Axle load unladen front/rear		kg	85 / 105
Wheels/suspension system	3.1	Tyres			Polyurethane (PU) / rubber
	3.2	Tyre size, front			Ø 100 x 40
	3.3	Tyre size, rear			Ø 230 x 65
	3.5	Wheels, number front/back (x=driven)			2 / 1x + 2
	3.6	Tread width, front	b ₁₀	mm	315
	3.7	Tread width, rear	b ₁₁	mm	370
Basic dimensions	4.9	Height of tiller handle in drive position min./max.		mm	835 / 1165
	4.12	Coupling height	h ₁₀	mm	150
	4.19	Overall length	l ₁	mm	700
	4.21.1	Overall width	b ₁	mm	480
	4.32	Ground clearance centre of wheelbase	m ₂	mm	35
	4.35	Turning radius	W _a	mm	570
Performance data	5.1	Travel speed laden/unladen		km/h	5.4 / 6
	5.1.1	Reverse travel speed with/without load		km/h	5.4 / 6
	5.5	Drawbar pull laden/unladen		N	200 / 200
	5.6	Max. drawbar pull laden/unladen		N	600 / 600
	5.10	Service brake			electromagnetic
E-motor/ Electronics	6.1	Drive motor, performance S2 60 min		kW	1
	6.4	Battery voltage/nominal capacity		V / Ah	24 / 63
	6.5	Battery weight		kg	46
Other	8.1	Type of drive control			3-phase AC technology
<p>- This data sheet according to VDI guideline 2198 only states the technical values of the standard truck. Different tyres, other masts, additional equipment etc. may result in different values.</p>					

- 4.12: With single plug-in coupling

The German production facilities in
Norderstedt, Moosburg and Landsberg
are certified.

ISO 9001
ISO 14001

Jungheinrich fork lift trucks meet
European safety requirements.



 **JUNGHEINRICH**

The Jungheinrich logo, featuring a red upward-pointing arrow above the word 'JUNGHEINRICH' in a bold, black, sans-serif font.