



Electric stand-on and sideways-seated stacker

ESD 220

Lift height: 1660 mm / Load capacity: 2000 kg

ESD 220

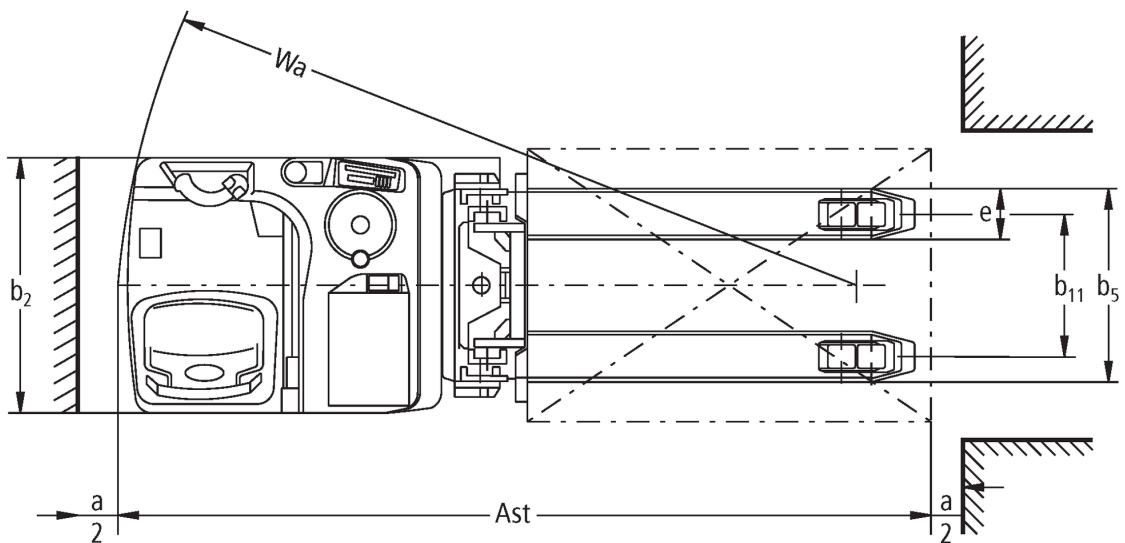
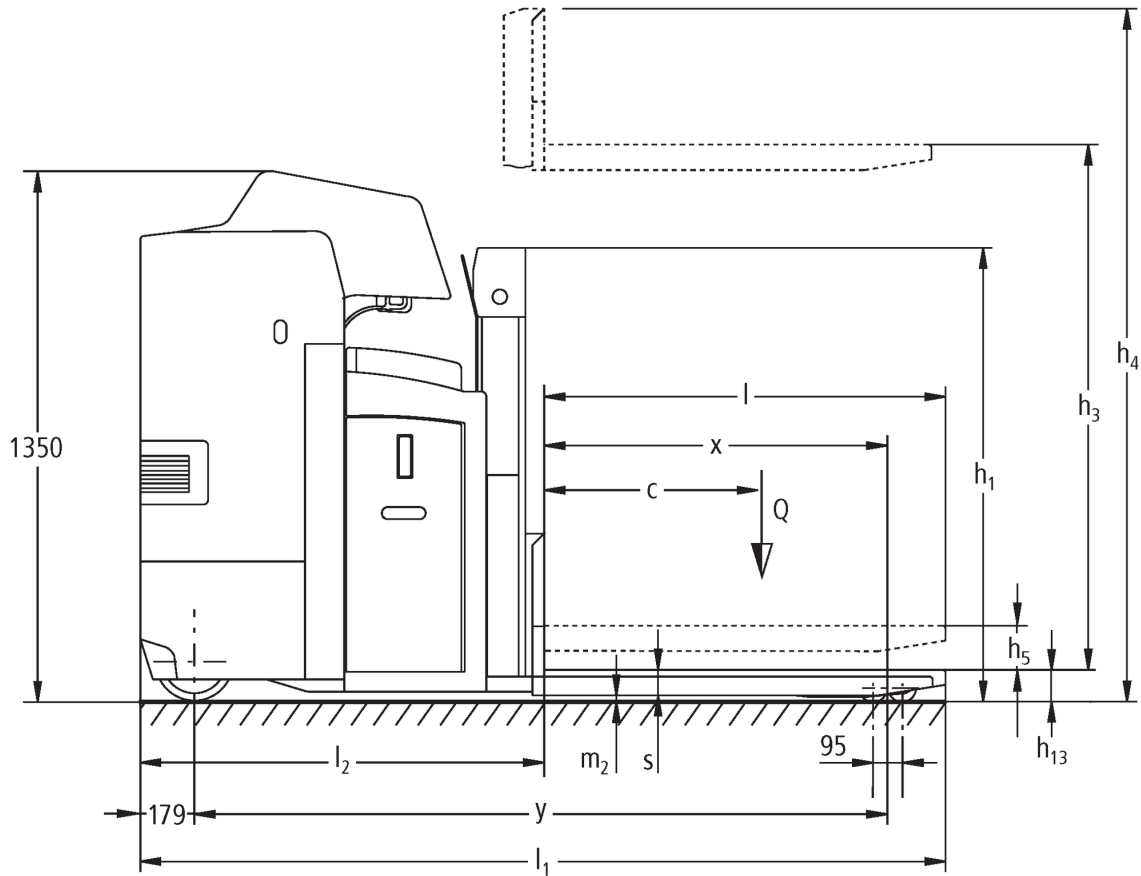

ESD 220

ESD 220	Lift (h3)	Retracted mast height (h1)	Free lift (h2)	Extended mast height (h4)
Duplex mast ZT	1660 mm	1310 mm	100 mm	2150 mm

VDI table

Stand-on: 11/2021

Characteristic	1.1	Manufacturer (abbreviated description)			Jungheinrich
	1.2	Manufacturer's type designation			ESD 220
	1.3	Drive			Electric
	1.4	Operation			Seat
	1.5	Load capacity/load	Q	kg	2000
	1.5.1	Rated capacity/load with mast lift	Q	kg	1000
	1.5.2	Rated capacity/load with support arm lift	Q	kg	2000
	1.6	Load centre distance	c	mm	600
	1.8	Load distance, centre of drive axle to fork	x	mm	926
1.9	Wheelbase	y	mm	1734	
Weights	2.1.1	Service weight (incl. battery)		kg	1350
	2.2	Axle load laden front/rear		kg	1340 / 2010
	2.3	Axle load unladen front/rear		kg	982 / 368
Wheels/suspension system	3.1	Tyres			Vulkollan®
	3.2	Tyre size, front			Ø 230 x 77
	3.3	Tyre size, rear			Ø 85 x 85
	3.4	Additional wheels			Ø 140 x 54
	3.5	Wheels, number front/back (x=driven)			2-1x/4
	3.6	Tread width, front	b ₁₀	mm	544
	3.7	Tread width, rear	b ₁₁	mm	380
Basic dimensions	4.2	Retracted mast height (h1)	h ₁	mm	1310
	4.3	Free lift (h2)	h ₂	mm	100
	4.4	Lift (h3)	h ₃	mm	1660
	4.5	Extended mast height (h4)	h ₄	mm	2150
	4.6	Initial lift	h ₅	mm	110
	4.8	Seat height/stand height	h ₇	mm	950
	4.15	Height, lowered	h ₁₃	mm	90
	4.19	Overall length	l ₁	mm	2185
	4.20	Length including fork shank	l ₂	mm	995
	4.21.1	Overall width	b ₁	mm	820
	4.22	Fork dimensions	s/e/l	mm	65 x 185 x 1190
	4.25	Width across forks	b ₅	mm	570
	4.32	Ground clearance centre of wheelbase	m ₂	mm	25
	4.34.1	Aisle width (pallet 800x1200 length)	A _{st}	mm	2399
4.35	Turning radius	W _a	mm	1925	
Performance data	5.1	Travel speed laden/unladen		km/h	9.1 / 9.1
	5.2	Lift speed laden/unladen		m/s	0.2 / 0.39
	5.3	Lowering speed laden/unladen		m/s	0.47 / 0.47
	5.8	Max. gradeability laden/unladen		%	8 / 14
	5.10	Service brake			generative
E-motor/Electronics	6.1	Drive motor, performance S2 60 min		kW	2.8
	6.2	Lift motor, performance with S3		kW	3
	6.3	Battery according to DIN 43531/35/36			no
	6.4	Battery voltage/nominal capacity		V / Ah	24 / 465
	6.5	Battery weight		kg	380
	6.6.1	Energy consumption according to EN cycle		kWh/h	0.61

	6.6.2	CO2 equivalent as per EN 16796	kg/h	0.3
Other	8.1	Type of drive control		AC
<p>- This data sheet according to VDI guideline 2198 only states the technical values of the standard truck. Different tyres, other masts, additional equipment etc. may result in different values.</p>				

- 1.5: for ESD 220: mast lift capacity: max. 1 t
- 1.8: for ESD 220: lowered load section: + 78 mm
- 1.9: for lowered load section: ESD 120 + 70 mm, ESD 220 + 78 mm
- 4.35: for ESD 220 lowered load section: + 78 mm

The German production facilities in
Norderstedt, Moosburg and Landsberg
are certified.

ISO 9001
ISO 14001

Jungheinrich fork lift trucks meet
European safety requirements.



 **JUNGHEINRICH**

The Jungheinrich logo, featuring a red upward-pointing arrow above the word 'JUNGHEINRICH' in a bold, black, sans-serif font.