



# **Electric stand-on and sideways-seated stacker**

## **ESD 120**

**Lift height: 1660-1960 mm / Load capacity: 2000 kg**

# ESD 120

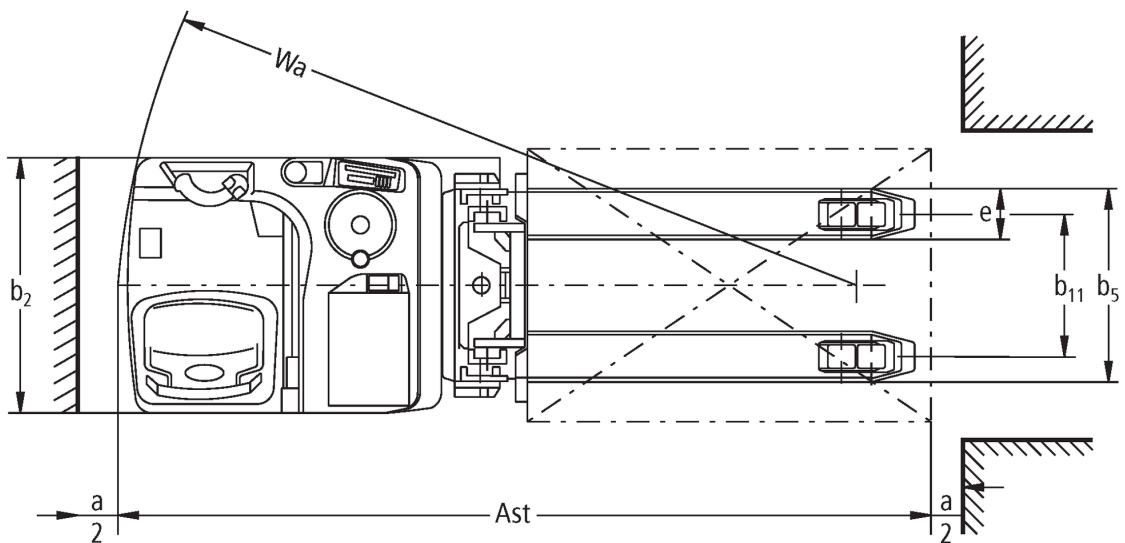
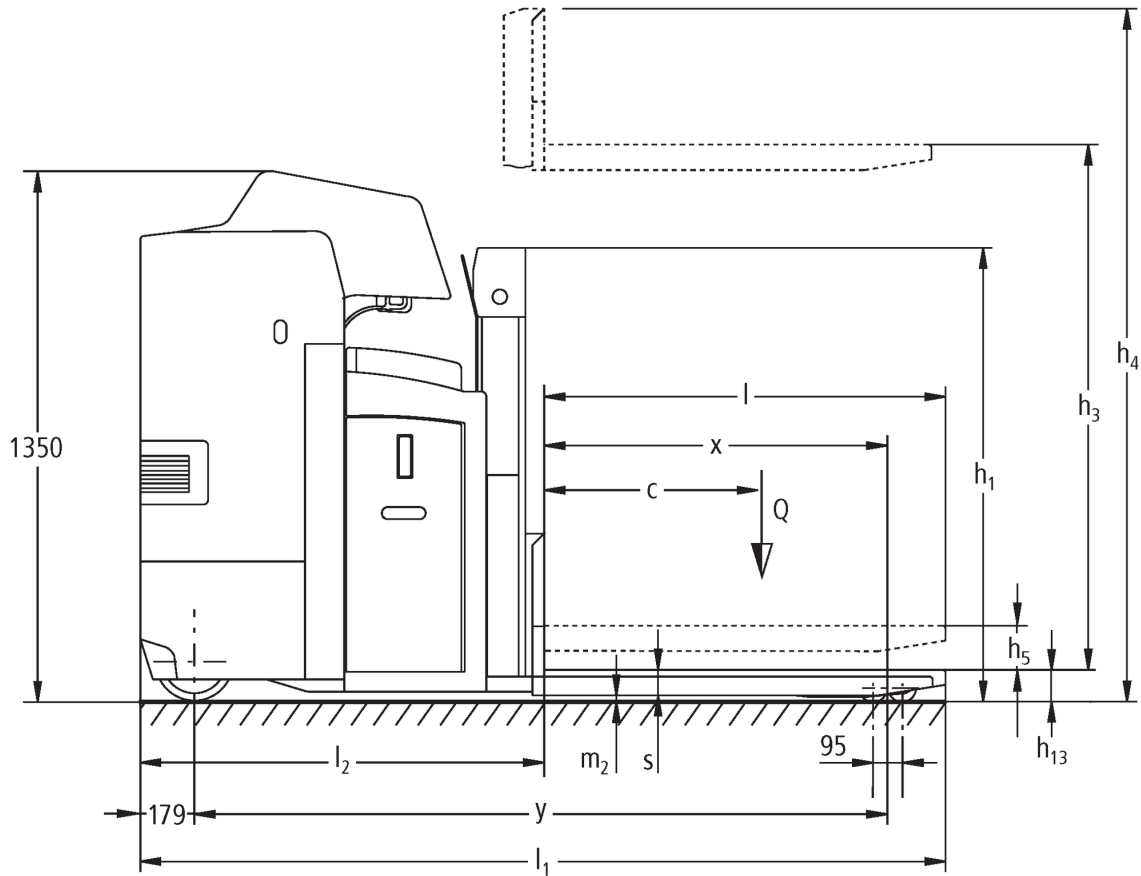

# ESD 120

ESD 120	Lift (h3)	Retracted mast height (h1)	Free lift (h2)	Extended mast height (h4)
Duplex mast ZT	1660 mm	1250 mm	100 mm	2200 mm
	1960 mm	1425 mm	100 mm	2500 mm

# VDI table

Stand-on: 11/2021

Characteristic	1.1	Manufacturer (abbreviated description)		Jungheinrich
	1.2	Manufacturer's type designation		<b>ESD 120</b>
	1.3	Drive		Electric
	1.4	Operation		Stand-on
	1.5	Load capacity/load	Q kg	2000
	1.5.1	Rated capacity/load with mast lift	Q kg	1000
	1.5.2	Rated capacity/load with support arm lift	Q kg	2000
	1.6	Load centre distance	c mm	600
	1.8	Load distance, centre of drive axle to fork	x mm	930
1.9	Wheelbase	y mm	1835	
Weights	2.1	Service weight	kg	1258
	2.1.1	Service weight (incl. battery)	kg	1258
	2.2	Axle load laden front/rear	kg	1220 / 2038
	2.3	Axle load unladen front/rear	kg	884 / 374
Wheels/suspension system	3.1	Tyres		Polyurethane (PU)
	3.2	Tyre size, front		Ø 230 x 77
	3.3	Tyre size, rear		Ø 85 x 75
	3.4	Additional wheels		Ø 140 x 57
	3.5	Wheels, number front/back (x=driven)		1 + 1x / 4
	3.6	Tread width, front	b <sub>10</sub> mm	485
	3.7	Tread width, rear	b <sub>11</sub> mm	380
Basic dimensions	4.2	Retracted mast height (h1)	h <sub>1</sub> mm	1250
	4.3	Free lift (h2)	h <sub>2</sub> mm	100
	4.4	Lift (h3)	h <sub>3</sub> mm	1660
	4.5	Extended mast height (h4)	h <sub>4</sub> mm	2200
	4.6	Initial lift	h <sub>5</sub> mm	105
	4.8	Seat height/stand height	h <sub>7</sub> mm	245
	4.15	Height, lowered	h <sub>13</sub> mm	90
	4.19	Overall length	l <sub>1</sub> mm	2260
	4.20	Length including fork shank	l <sub>2</sub> mm	1070
	4.21.1	Overall width	b <sub>1</sub> mm	760
	4.22	Fork dimensions	s/e/l mm	60 x 190 x 1190
	4.25	Width across forks	b <sub>5</sub> mm	570
	4.32	Ground clearance centre of wheelbase	m <sub>2</sub> mm	20
	4.34.1	Aisle width (pallet 800x1200 length)	A <sub>st</sub> mm	2485
	4.35	Turning radius	W <sub>a</sub> mm	2015
Performance data	5.1	Travel speed laden/unladen	km/h	10 / 12
	5.2	Lift speed laden/unladen	m/s	0.14 / 0.22
	5.3	Lowering speed laden/unladen	m/s	0.23 / 0.17
	5.8	Max. gradeability laden/unladen	%	6 / 12
	5.10	Service brake		generative
E-motor/Electronics	6.1	Drive motor, performance S2 60 min	kW	2.8
	6.2	Lift motor, performance with S3	kW	2.2
	6.3	Battery according to DIN 43531/35/36		B
	6.4	Battery voltage/nominal capacity	V / Ah	24 / 375
	6.5	Battery weight	kg	297
	6.6.1	Energy consumption according to EN cycle	kWh/h	0.66

	6.6.2	CO2 equivalent as per EN 16796	kg/h	0.4
Other	8.1	Type of drive control		AC
- This data sheet according to VDI guideline 2198 only states the technical values of the standard truck. Different tyres, other masts, additional equipment etc. may result in different values.				

The values in the table apply to battery compartment L-SBE, mast ZT1660, support arm lift raised.

- VDI no. 1.5: In double-decker operation: mast lift max. 1 t / total load max. 2 t.
- VDI no. 1.5.2: In double-decker operation: mast lift max. 1 t / total load max. 2 t.
- VDI no. 1.8: Support arm lift lowered:  $x + 70$  mm.
- VDI no. 1.9: Support arm lift lowered:  $y + 70$  mm. With battery compartment XL-SBE:  $y + 72$  mm.
- VDI no. 4.19: With battery compartment XL-SBE:  $l1 + 72$  mm.
- VDI no. 4.20: With battery compartment XL-SBE:  $l2 + 72$  mm.
- VDI no. 4.34.1: With battery compartment XL-SBE:  $Ast + 72$  mm.
- VDI no. 4.35: Support arm lift lowered:  $Wa + 70$  mm. With battery compartment XL-SBE:  $Wa + 72$  mm.

The German production facilities in  
Norderstedt, Moosburg and Landsberg  
are certified.

ISO 9001  
ISO 14001

Jungheinrich fork lift trucks meet  
European safety requirements.



 **JUNGHEINRICH**

The Jungheinrich logo, featuring a red upward-pointing arrow above the word 'JUNGHEINRICH' in a bold, black, sans-serif font.